

METHOD STATEMENT – RISK ASSESSMENT USING A VERTICAL BALER MACHINE



ASSESSMENT DETAILS

Method Statement Reference:	CCRM-034	FREQUENCY (TICK AS APPROPRIATE)				
Issue Number	12	Daily	Weekly	Monthly	Quarterly	Yearly
Task:	Using a Vertical Baler Machine					
Date Completed:	2 March 2026	✓				
Employee consultation and involvement:	Jhon Otalvaro					
Re-Assessment Due*:	One year from above date					
Method Statement Completed By:	Health & Safety Manager	Emergency Telephone Number: information service: 111 (24 hours) Emergency: 999				

STEP 2 – PERSONEL REQUIRED (DURING ACTIVITY)

Lone Worker	2 or More Persons	First Aider	Supervisor/Team Leader	Management
✓	✓	N/A	N/A	N/A

STEP 3 – PROCEDURES TO BE CARRIED OUT (BEFORE STARTING WORK)

Training and Knowledge Company Safety Site -Induction Form- F039	Only Trained and Certified Operatives on The Use Of The Equipment	Read and Review The Equipment Manual	Perform Visual Safety Check of Equipment F046	Test Emergency Stop Buttons / Isolator Switches	Place Warning Signs	Visual Safety Check of PPE REFER TO STEP 4
✓	✓	✓	✓	✓	✓	✓

STEP 4 – HAZARDS, PRODUCT AND PPE:

Slips, Trips & Falls	Vehicles	Electric Shock	Fire Risk	Manual Handling	S2 Safety Boots	Heavy Duty Gloves	Hi-Visibility Vest	Eye Protection
✓	✓	✓	✓	✓	✓	✓	✓	✓

STEP 5 – PRODUCT USAGE

Product Name	Product Usage	Product Type	Usage Dilution	Mix with other products	Application / Equipment
N/A	N/A	N/A	N/A	N/A	N/A



STEP 6 – METHOD STATEMENT SAFETY

1. Only employees who have been trained on the use of the compactor can engage on this activity
2. Read and Familiarize with the equipment manual.
3. Wear personal protective equipment (Heavy Duty Gloves, Safety Boots, High Vis Vest, Goggles).
4. Use correct lifting techniques when moving objects and waste bags.
5. Compactor keys must be removed after every operation and returned to security after every shift.
6. A visual safety check (F046) must be performed by the operative before the operation of this equipment
7. **NEVER operate** the baler if any deficiencies are found during your visual check with F046. Any malfunction or broken components must be **reported immediately and the machine "TAG" out of service.**
8. It is responsibility of the employee to perform the visual safety check (F046) and report any malfunction, defects, and faults of the equipment to his/her superior.
9. The Employee must also *use the equipment, in accordance with the training and instructions given. The employee also **MUST inform the company** of any work situation which represents **a serious and imminent danger to health and safety** and to inform their employer of any matter which represent a shortcoming in the employer's protection arrangements for health and safety*
10. Do not attempt to repair, replace or interfere with any part of the equipment
11. Only authorized (trained) personnel are present at the site of operation and within the danger zone of the baler which is shown below.

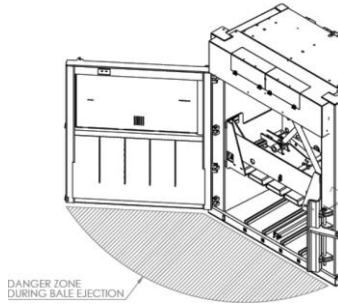

12. **Only compact cardboard, plastics, textiles. DO NOT try to compact wood, pressure vessels, concrete, metals etc.**
13. DO NOT climb on the baler at any time.
14. Stand away from the front of the baler during compaction.
15. Keep wire, cutters & other tools away from the baler when unloading.
16. Never allow liquids near the electrical controls.
17. Clean the baler and the floor area when finished. Avoid collecting dust on the floor to prevent slips and falls.

METHOD

1. Put on personal protective equipment (Pls. look Step 4).
2. Assemble equipment and check for safety.
3. Place warning signs.
4. Performed visual safety check (F046)
5. **Test emergency stop buttons / isolator switches**
6. Press the green forward start button
7. With the ramp in up position insert a flat piece of cardboard on top of the bale (this will provide a flat surface for tying) After cycle complete check if the material has been process
8. Close safety gate, operate down command button
9. **If you need to clear up scrap from the top of the ramp, following the compression stroke. USE the long grab or litter picker for the removal". So you DO NOT HAVE TO LEAN into the machine.**
10. The compression ramp will automatically stop full down stroke. Blue light will come on indicating a FULL Baler

METHOD STATEMENT – RISK ASSESSMENT USING A VERTICAL BALER MACHINE



11. Turn machine OFF.!" Unlock wheel and open chamber door. "DO NOT stand in front of the door when opening...!". YELLOW light will come on. Indicating two hand switch operation for Bale extraction
12. Pull wire down along the bale and cut a length approx. 50 cm or ¾ from the top of the bale down
13. Be careful when suing baling wire. The sharp (cut) end should always be facing down to avoid cuts.
14. Take tool provided and slide wire through slots in compression ramp
15. Loose the wire fastened on the hook in the chamber tray. And tie this with the end of the wire (step 7).
16. Position pallet in front of chamber (use a BLUE pallet if possible)
17. Lift compression plates UP
18. Feed new wire through the gaps at the base of the chamber tray use tool provided and tide new loop knots
19. Close chamber gate and tighten door lock wheel
20. Open safety gate and load cardboard until blue indicator comes on. **DO NOT FORGET material must be loaded evenly.**
21. **DO NOT** try to pull the bale until the bale has been ejected and the motor has stopped.



22. In Case of Danger Press the Emergency Stop Button or Remove The Plug From The Mains.

During training refers to V-PRESS BALING INDUCTION MANUAL form (F075)

CARE OF EQUIPMENT

1. Turn the machine OFF / isolate machine when attempting to clean debris or sweep from inside the compartment
2. Keep free of dirt using a damp cloth or brush.
3. DO NOT USE a power hose to remove dirt
4. Check oil level on the side gage

STEP 7. RISK ASSESSMENT (Frequency X Severity = Risk)

CATEGORY	HAZARD	POTENTIAL HARM	LIKELIHOOD	Severity	Risk before Controls	Risk After Controls	COMMENTS/ACTIONS
Vehicles	Vehicles manoeuvring, or steering in Loading bay, car parks, courtyards areas, etc.	Broken bones/bruises /cuts/ death	4	4	16	4	<ul style="list-style-type: none"> • All operatives wear high visibility clothing • All operatives are trained and qualified in safe practices when working around vehicles and are aware of any danger areas • Full PPE provided Incl Safety boots • Safety/warning signs

METHOD STATEMENT – RISK ASSESSMENT USING A VERTICAL BALER MACHINE



Use of Electrical Equipment (Using Electrically Powered Compactor)	Electrocution	Electrocution/ burns/death	4	3	12	3	<ul style="list-style-type: none"> All staff involved in using the compactor are trained in its safe use and the electrical isolation points The compactor is visually inspected with F046 prior to use by the operator All on site electrical equipment is routinely tested and maintained by the collection company Records of formal visual inspections and maintenance tests are logged
Mechanical Failure	Injury to persons from ejected material	Cuts/bruises/ shrapnel may become embedded in a person/splinters	2	3	6	3	<ul style="list-style-type: none"> Only suitable material (cardboard, plastics, textiles) placed into the compactor. Wood, builder's materials, glass and hazardous waste must not be placed into the compactor The compactor must not be over filled When the red 'full' indicator light comes on no more waste should be placed into the compactor The compactor is to be routinely maintained in accordance with manufacturer's guidelines The compactor must be visually inspected by the user before use and in the event the unit appears damaged TAG out of service and Report to Area Manager Immediately
Contact with Moving Parts	Entanglement/ pinching	Crushing/ injuries	3	4	12	4	<ul style="list-style-type: none"> Operatives are not to climb in, on or under the compactor for any reason The door must be fully closed when operating the compactor. If the interlock between the door and the power supply appears to be malfunctioning TAG out of service and Report to Manager Immediately If there is a blockage or other problem preventing the compactor from working properly. TAG out of service and Report to Manager Immediately Under no circumstances should the operator attempt to remove the blockage or fix the problem Operatives Provided with long grab or litter pickers for the removal of cardboard scraps following the compression stroke so that the operator does not have to lean into the machine.
Contact with Moving Parts	Chamber door opening under abnormal pressure	Crushing/ injuries	3	4	12	4	<ul style="list-style-type: none"> Only trained operatives authorised to use the machine Emergency stop button Visual safety checks before commencing If there is a blockage or other problem preventing the compactor from working properly. TAG out of service and Report to Manager Immediately The door must be fully closed when operating the compactor. If the interlock between the door and the power supply appears to be malfunctioning TAG out of service and Report to Manager Immediately
Environmental Exposure	Extreme weather conditions	Risk of Heat Exhaustion/ Hypothermia	2	3	6	3	<ul style="list-style-type: none"> All staff involved in working out doors are provided with a comprehensive range of appropriate clothing and Personal Protective Equipment

METHOD STATEMENT – RISK ASSESSMENT USING A VERTICAL BALER MACHINE



Chemical Spillage	Potentially toxic and harmful substances released from unauthorised dumping of waste	Inhalation/ingestion/absorption	3	4	12	4	<ul style="list-style-type: none"> All staff are trained and aware of only suitable material will be placed into the compactor All staff are trained and aware of the hazards associated with the potential harmful contents of the compactor System of work for dealing with spillages and other chemicals is in place along with appropriate PPE (mask, gloves & goggles to be worn during cleanup operations) All cleaning chemicals have corresponding COSHH data sheets and individual Risk Assessments and Method Statements All staff are trained in the safe use, storage and handling of cleaning chemicals and cleaning of spillages
Oiled spillage	Slips / trips	Injuries	3	3	9	3	<ul style="list-style-type: none"> Visual safety checks before commencing the machinery TAG OUT Of SERVICE and Reporting in place for all Malfunctions / Faults Only trained personnel authorised to use
Fitting Bailer wire	Sharp edges / cutting, puncturing & piercing ends	Cuts to hands Injuries to eyes	4	3	12	3	<ul style="list-style-type: none"> Gloves supplied to operatives Goggles supply to operatives Infrequent operations
Manual Handling	Pulling&pushing of the bale, awkward positions during fitting baler wire	Musculoskeletal disorders	3	4	12	4	<ul style="list-style-type: none"> All operatives are trained about proper pulling and pushing techniques Only trained operatives authorised to use
BALE ejection	Broken pallet Uneven ejection of bale Broken pump track Clearing blockages / freeing any bales that do not eject properly	Crushing Injuries / Musculoskeletal injuries to back, lower or upper limbs	4	3	12	3	<ul style="list-style-type: none"> All staff are trained and aware of the hazards associated with Bales Operatives must inspect palet and pump truck before the ejection of the bale and report any faults. TAG OUT Of SERVICE and Reporting in place for all Malfunctions / Faults Boots with toe protectors worn for large bales (See step 4) Operatives stands to side of machine to eject bale (controls location side of machine) Pallet truck used/ Bale on pallets only moved a few metres Gloves Provided Operatives Provided with long grab or litter pickers for the removal of cardboard scraps following the compression stroke so that the operator does not have to lean into the machine.

METHOD STATEMENT – RISK ASSESSMENT USING A VERTICAL BALER MACHINE



Physical Injury	Lone working Risk of physical assault Sharp objects in refuse bags and staples in cardboard boxes	Broken bones/bruises /cuts/ psychological trauma	2	3	6	3	<ul style="list-style-type: none"> CCTV is in operation in work area Operatives always carry a mobile phone to raise emergencies Gloves to be worn when needed. Where possible work on lights to be carried out when lamps are off and cold Operatives are aware of the dangers and wear appropriate PPE 		
OVERALL RISK RATING BEFORE CONTROL: –			10.6	Very Low	Low	Medium	High	COMMENTS	
OVERALL RISK RATING AFTER CONTROL: –			3.4	Very Low	Low	Medium	High		
LIKELIHOOD 1. IMPROBABLE OCCURRENCE 2. REMOTED OCCURRENCE 3. REASONABLY PROBABLE OCCURRENCE 4. VERY LIKELY OCCURRENCE 5. ALMOST CERTAIN OCCURRENCE		SEVERITY 1. SLIGHT: NO INJURY or Injury requiring first Aid treatment 2. MINOR: INJURY requiring medical treatment with absence from 3 days to 3 weeks 3. MODERATE: Injury illness resulting in temporary disability (eg. fractures) and absence over 3 weeks 4. SERIOUS: Severe injury or permanent disability (e.g loss of limb, sight) property and equipment damage 5. MAJOR: Immediate danger exist, capable of causing death, loss or damage on a wide scale and serious business disruption (e.g. Explosion, fire, structural damage, etc.)					INTERPRETATION 4 and below very Low risk = No further action, but ensure controls are maintained an review 5 to 8 Low risk = Risk Can be tolerated or for only short term. Plan introduction of measures with a define time period 9 to 15 Medium Risk = Planned and introduce further control measures to mitigate the risk within a time scale 16 and Above = Stop activity and immediate action		